

DESCRIPTION

AMCOM's AM153040WM-BM/FM-R is part of the GaAs HIFET MMIC power amplifier series. It is a 2-stage GaAs HIFET PHEMT MMIC power amplifier. It is fully matched to 50-ohm at both input and output, covering 1.4 to 3.4GHz. The MMIC has 18dB gain and 38dBm output power at 12V. This MMIC is in a ceramic package with both RF and DC leads at the lower level of the package to facilitate low-cost SMT assembly to the PC board. When mounting directly to PCB, please see application note AN700 for instructions. Because of high DC power dissipation, we strongly recommend to mount these devices directly on a metal heat sink. The AM153040WM-FM-R is the AM153040WM-BM-R mounted on a gold plated copper flange carrier. There are two screw holes on the flange to facilitate screwing on to a metal heat sink. This MMIC is RoHS compliant.

FEATURES

- Frequency applications from 1.4 to 3.4GHz
- High output power, P1dB = 37dBm
- Gain = 18dB
- Input & Output matched from 1.4GHz to 3.4GHz

APPLICATIONS

- PCS Base Station
- GPS Applications
- MMDS
- WLAN Repeaters
- 10V – 13V Applications

TYPICAL PERFORMANCE ON A TEST BOARD*

Performance at $V_{dd} = +12V$, $V_{gs} = -0.90V^{}$, $I_{dq} = 1300mA$, $T_a = 25^{\circ}C$**

| Parameters | Minimum | Typical | Maximum |
|--------------------|--------------|--------------|---------|
| Frequency | 1.8 – 3.0GHz | 1.4 – 3.4GHz | |
| Small Signal Gain | 14dB | 18dB | |
| Gain Ripple | | ± 2.0dB | ± 3.0dB |
| P1dB | 35.0dBm | 37dBm | |
| Psat | | 38dBm | |
| IP3 | | 43dBm | |
| Efficiency @ P1dB | | 30% | |
| Input Return Loss | 10dB | 15dB | |
| Output Return Loss | 6dB | 10dB | |
| Thermal Resistance | | 5°C/W | |

*Specifications subject to change without notice.

** V_{gs} may vary from lot to lot

ABSOLUTE MAXIMUM RATING

| Parameter | Symbol | Rating |
|--|-----------|-----------------|
| Drain source voltage | V_{dd} | 13V |
| Gate source voltage | V_{gs} | -5V |
| Drain source current | I_{dd} | 2.0A |
| Continuous dissipation at room temperature | P_t | 25W |
| Channel temperature | T_{ch} | 175°C |
| Storage temperature | T_{sto} | -55°C to +135°C |

SMALL SIGNAL DATA ($V_{dd} = +12V$, $V_{gs} = -0.90V^{}$, $I_{dq} = 1300mA$, $T_a = 25^\circ C$)**

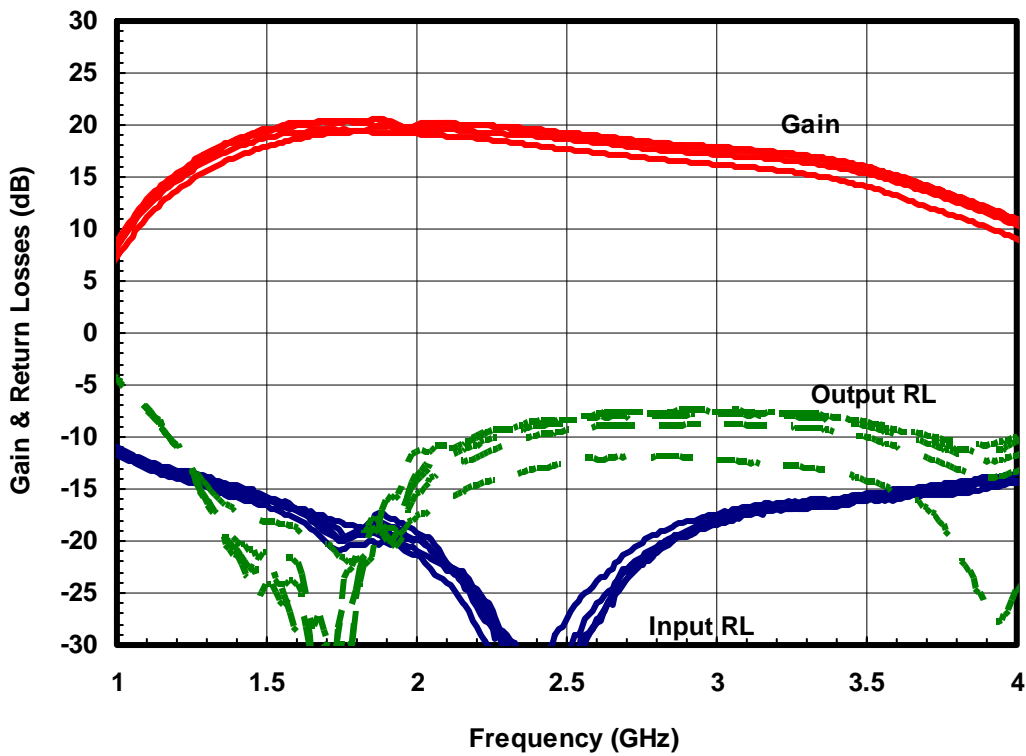

** V_{gs} may vary from lot to lot

POWER DATA ($V_{dd} = +12V$, $V_{gs} = -0.90V^{**}$, $I_{dq} = 1300mA$, $T_a = 25^{\circ}C$)

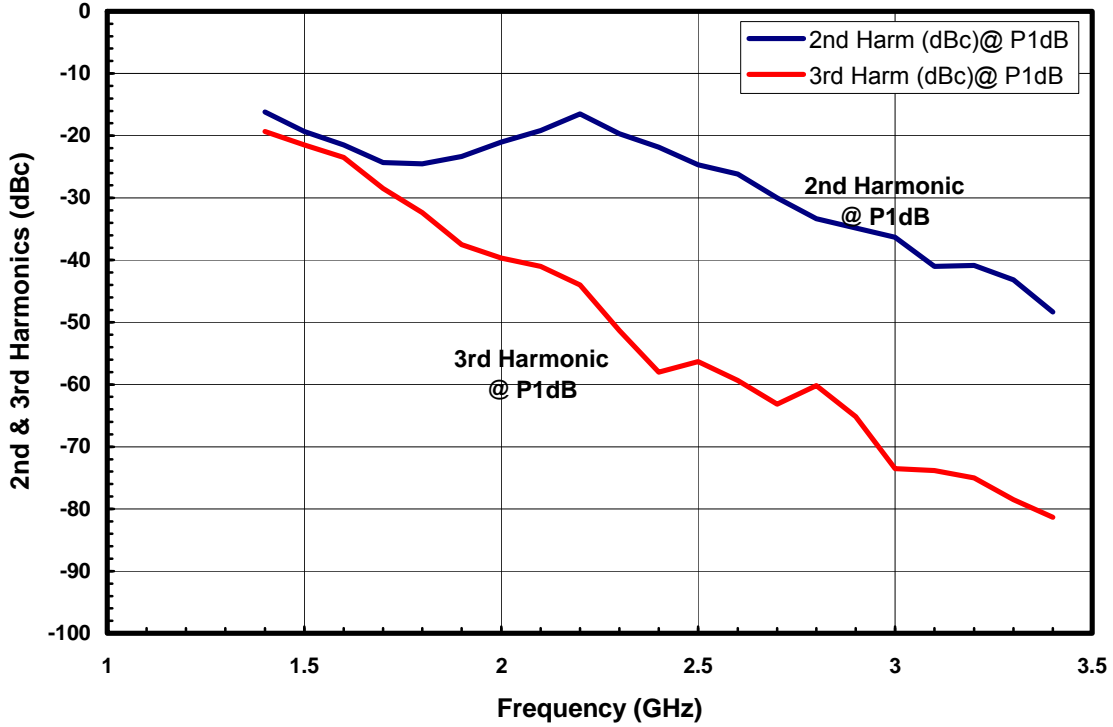
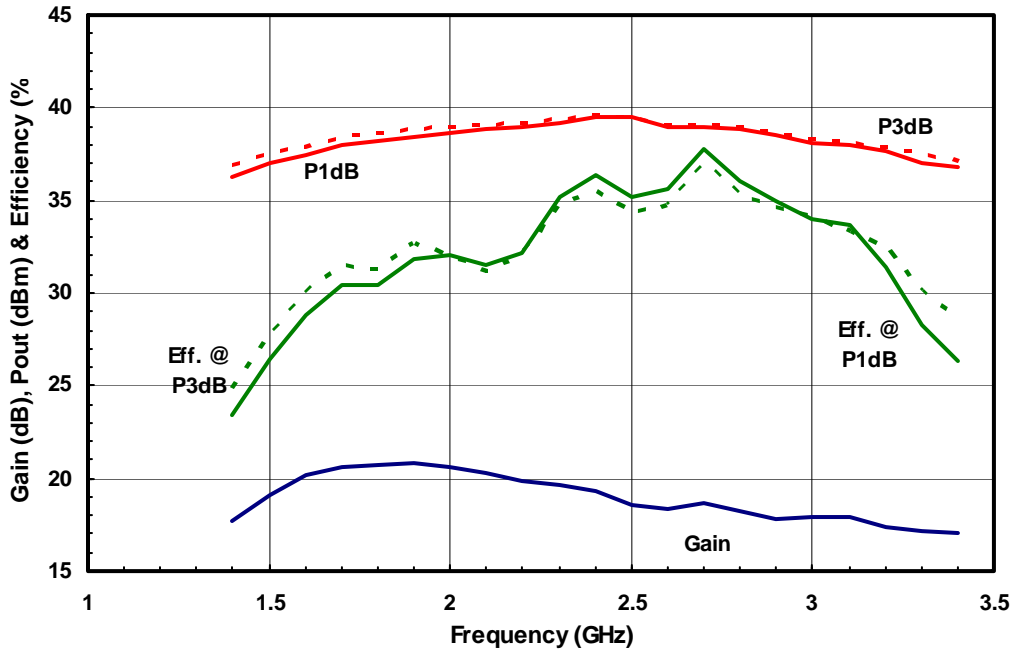

** V_{gs} may vary from lot to lot

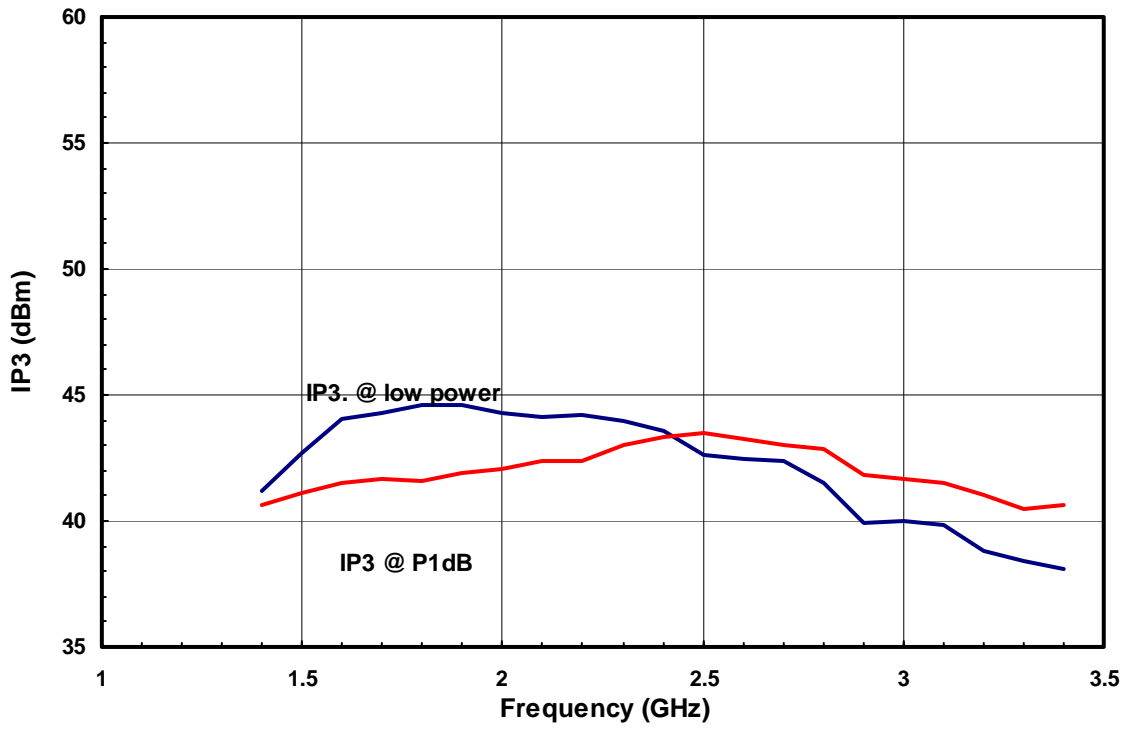

PACKAGE OUTLINE (BM)

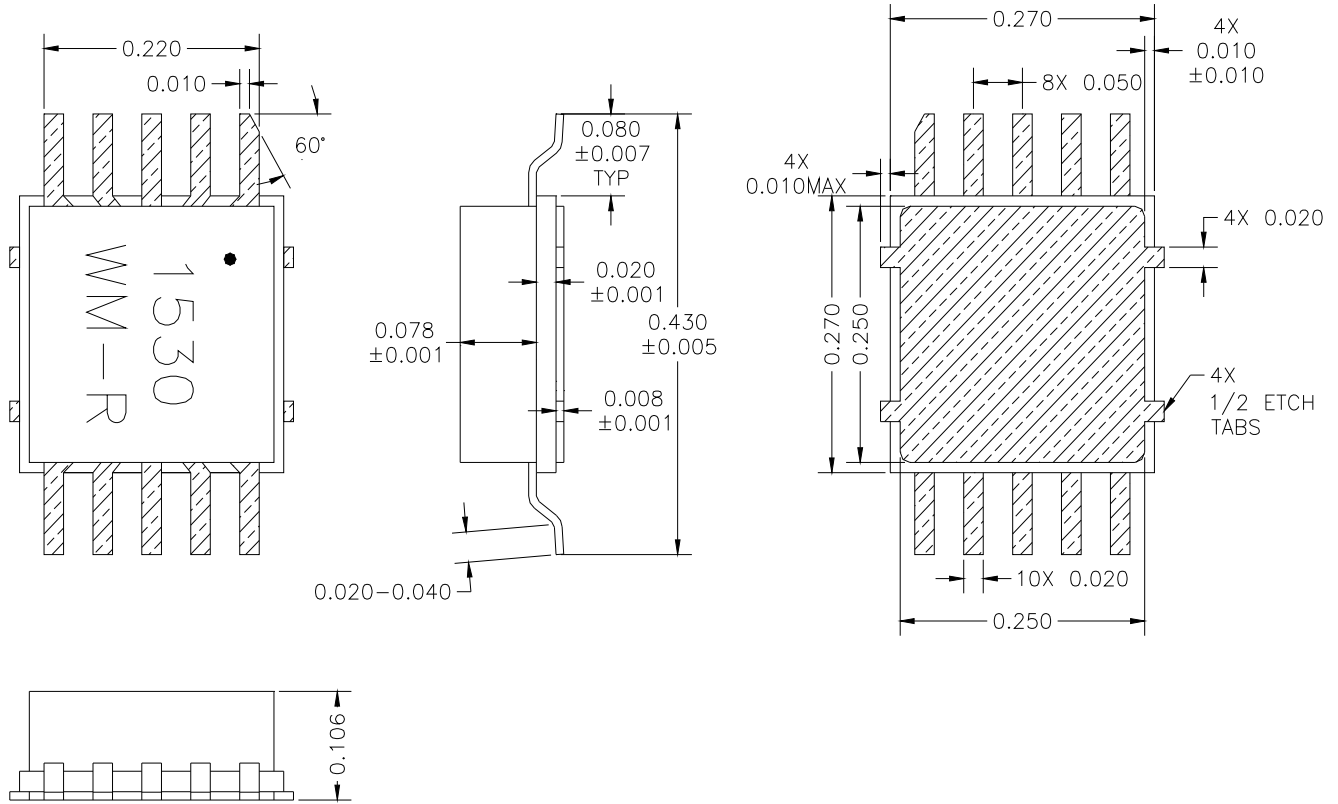

PIN LAYOUT

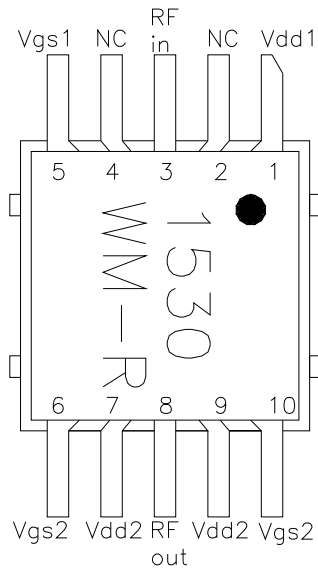

| Pin No. | Function | Bias* |
|---------|----------|-------|
| 1 | Vdd1 | +12V |
| 2 | NC | |
| 3 | RF in | |
| 4 | NC | |
| 5 | Vgs1 | -0.9V |
| 6 | Vgs2 | -0.9V |
| 7 | Vdd2 | +12V |
| 8 | RF out | |
| 9 | Vdd2 | +12V |
| 10 | Vgs2 | -0.9V |

* V_{gs1} & V_{gs2} may vary from lot to lot

PACKAGE OUTLINE (FM)

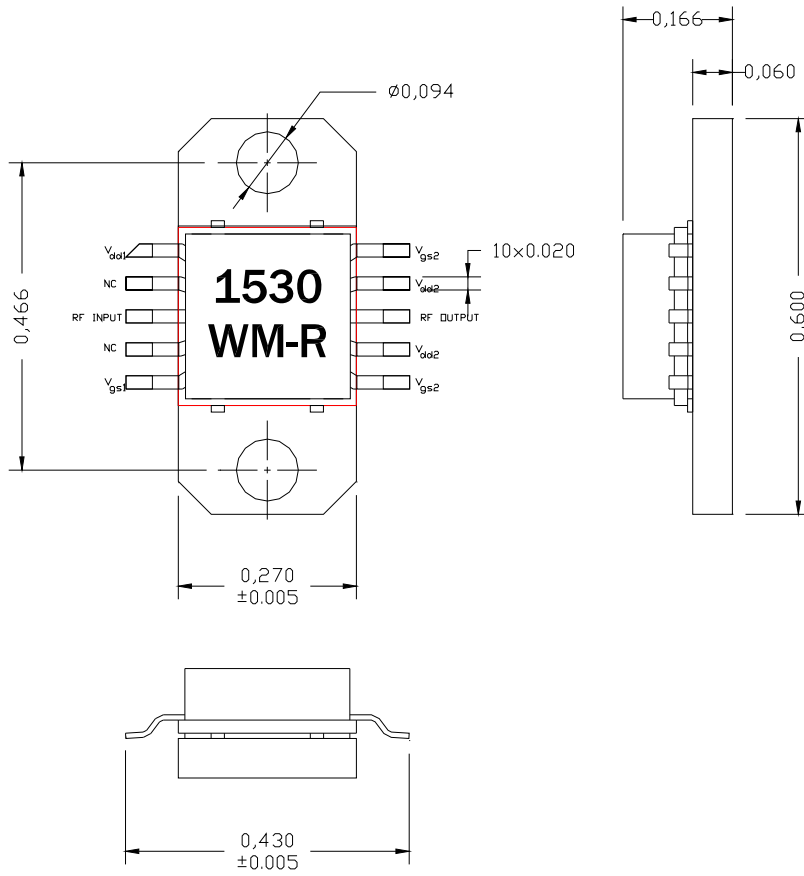

PIN LAYOUT

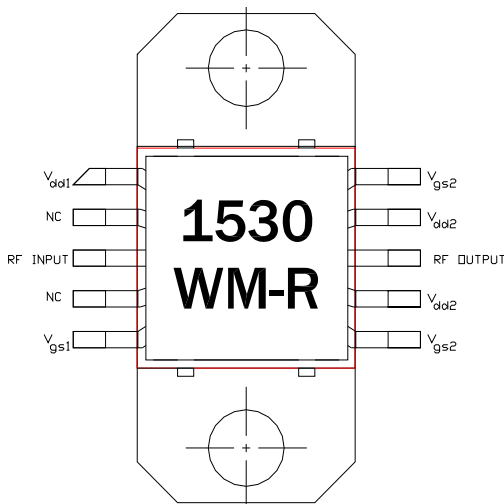

| Pin No. | Function | Bias* |
|---------|----------|-------|
| 1 | Vdd1 | +12V |
| 2 | NC | |
| 3 | RF in | |
| 4 | NC | |
| 5 | Vgs1 | -0.9V |
| 6 | Vgs2 | -0.9V |
| 7 | Vdd2 | +12V |
| 8 | RF out | |
| 9 | Vdd2 | +12V |
| 10 | Vgs2 | -0.9V |

* V_{gs1} & V_{gs2} may vary from lot to lot

TEST CIRCUIT for BM package

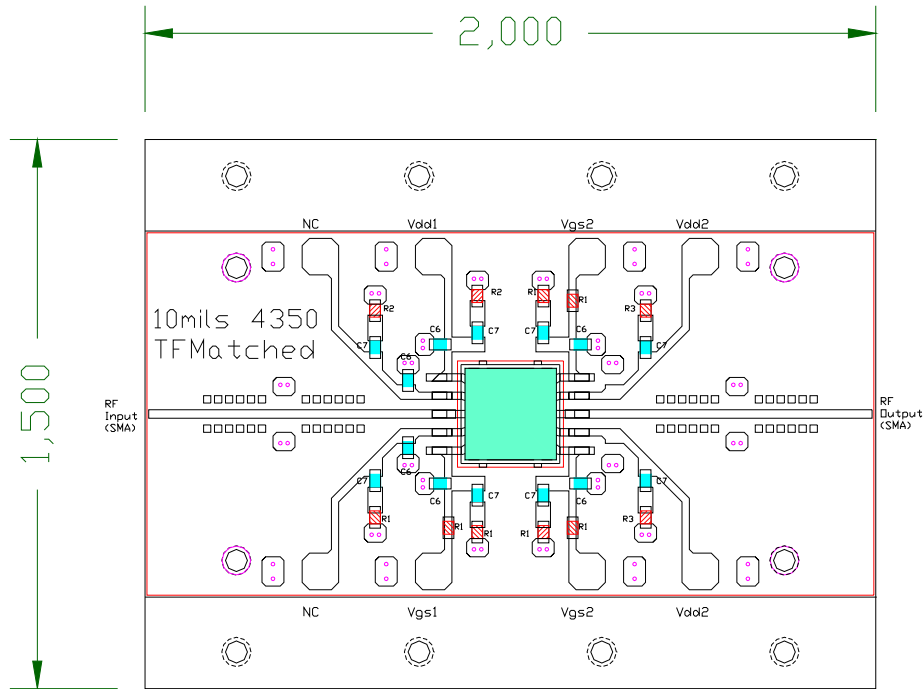

- Notes:
- 1- 10mils Rogers 4350 Material epoxied
 - 2- Ckt is for matched MMICs
 - 3- C6=20pF, C7=1000pF,
 R1=50ohms, R2=10ohms, R3=5ohms
 - 4- All Caps & Resistors are 0603 size

Important Notes:

- 1- The MMIC should have a good heat sink to avoid overheating. MMIC should be attached on direct ground for lowest junction temperature.
- 2- If surface mount is used, use PC board thickness < 10mils and ensure vias are filled with solder or metal to lower PCB heat resistance. For surface mount the MMC should be de-rated to a maximum +10V bias.
- 3- Recommended current biases are 300mA & 1000mA for the first and second stages respectively.
- 4- Do not apply V_{dd1} & V_{dd2} without proper negative voltages on V_{gs1} & V_{gs2} .
- 5- The currents flowing out of the V_{gs1} & V_{gs2} pins are less than 2mA & 12mA at P_{1dB} .
- 6- External 1 μ F dipped tantalum capacitor should be attached to Vd and Vg to decouple external bias leads.

TEST CIRCUIT for FM package

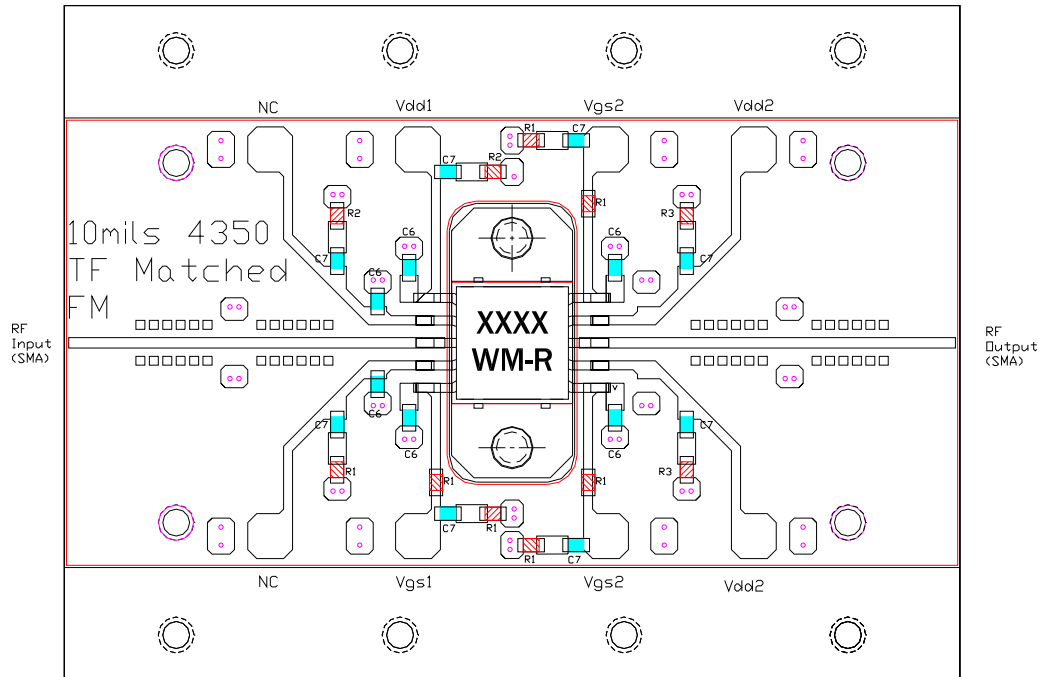

- Notes:
- 1- 10mils Rogers 4350 Material epoxied
 - 2- Ckt is for matched MMICs
 - 3- C6=20pF, C7=1000pF,
 R1=50ohms, R2=10ohms, R3=5ohms
 - 4- All Caps & Resistors are 0603 size
 - 5- External 1 μ F dipped tantalum capacitor should be attached to Vd and Vg to decouple external bias leads.